

Model 52U



**Electronic display
voltage-powered dual
function counter with
4 functions**



WARNING: Read page 2 first

Operating instructions

Electronic display counter

CODIX 52U

1.1 Safety instructions and warnings

Only use this display



- in a way according to its intended purpose
- if its technical condition is perfect
- adhering to the operating instructions and the general safety instructions.

1.2 General safety instructions

1. Before carrying out any installation or maintenance work, make sure that the power supply of the digital display is switched off.
2. Only use this digital display in a way according to its intended purpose: If its technical condition is perfect. Adhering to the operating instructions and the general safety instructions.
3. Adhere to country or user specific regulations.
4. The digital display is not intended for use in areas with risks of explosion and in the branches excluded by the standard EN 61010 Part 1.
5. The digital display shall only operated if it has been correctly mounted in a panel, in accordance with the chapter "Main technical features".

1.3 Use according to the intended purpose

The digital display may be used only as a panel-mounted device. Applications of this product may be found in industrial processes and controls, in manufacturing lines for the metal, wood, plastics, paper, glass, textile and other processing industries. Over-voltages at the terminals of the digital display must be kept within the limits in Category II

If the digital display is used to monitor machines or processes in which, in case of a failure of the device or an error made by the operator, there might be risks of damaging the machine or causing accidents to the operators, it is your responsibility to take appropriate safety measures.

1.4 Description

CODIX 52U is a multipurpose device. Depending on the programmed basic function, the device operates like

- an **electronic totaliser and frequency meter** (see page 2)
- an **electronic display counter with 2 totalising ranges** (see page 4)
- an **electronic totaliser and time meter** (see page 6)
- an **electronic time meter with 2 time ranges** (see page 9)

2. Setting of the operating parameters

- a. Press both front side keys and switch on the supply voltage or, if the supply voltage is already on, press both keys simultaneously during 5 s.

- b. The display shows

- c. After releasing the keys, the display shows

- c1. Hold the left key pressed and press the right key to leave the programming operation.

- c2. Press the right key to switch to

- d. Hold the left key pressed and press the right key to switch to the first parameter.

- e. After releasing the keys, the display alternates between the menu title and the current menu item setting. After pressing any key, only the menu item setting is displayed.

- f. Pressing the right key, the menu item setting will be switched to the next value. If figures are to be input (e.g. when setting the scaling factor), select first the decade using the left key, and then set the value using the right key.

- g. Hold the left key pressed and press the right key to switch to the next menu item.
- h. The last menu title "EndPro" allows, when selecting "Yes", to exit the programming menu and to take over (store) the new values. If "no" is selected, the programming routine is repeated, the latest values set remaining active. They can now be checked again or modified.

3. Programming routine

The first menu item is the selection of the basic operating mode, which determines the functions of the device.

P n o d E

t o t t R c

Operating mode adding counter and frequency meter, continued in point 4 on page 2

t o t t o t

Operating mode display counter with 2 totalising ranges, continued in point 4 on page 4

t o t t i

Operating mode totaliser and time meter, continued in point 4 on page 6

t i t i

Operating mode time meter with 2 time ranges, continued in point 4 on page 9

Electronic totaliser and frequency meter

Codix 52U: basic operating mode

t o t t R c

1. Description

- 6-digit totaliser and frequency meter
- Red LED display, character height 8 mm
- Display range 0 ... 999 999
- Leading zeros suppression
- Programming via two setting keys on the front side
- During programming, the display guides the user with text prompts
- Value conversion and display in 1/s oder 1/min

2. Inputs

INP A

Dynamic count/frequency input.

RESET

Dynamic RESET input. Linked in parallel to the red RESET key. Resets the counter to zero.

3. Selection of the displayed value

Pressing the right key allows switching between the totaliser display and the frequency meter display. Press the key briefly to display for 2 seconds the current function ("total" or "tacho"). If, during this period of time, the right key is pressed a second time, the device switches to the next function and displays a confirmation ("total" or "tacho") for 2 seconds. Then, the value of the selected function is displayed.

4. Programming routine

The programmable parameters of the device are described below, in the order in which they can be set. The device is fully programmed after one pass of the routine.

The first values stated correspond to the factory setting

4.1 Polarity of the inputs

i n P o l

n P n

npn: switching for 0 V

P n P

pnp: switching for +U_B

4.2 Switching on the 30 Hz filter (INP A)

F i l t e r

The filter provides input damping*

o F F

30 Hz filter off (f_{max})

o n

30 Hz filter on

4.3 Multiplying factor (totaliser)

F R c t o t

0 1 0 0 0 0

It can be set from 00.0001 up to 99.9999.

9 9 9 9 9 9

The decimal point is set to 4 decimal places. „0“ is not accepted!

* where bounce occurs, e.g. with contacts

4.4 Dividing factor (totaliser)

d i u t o t

0 1 0 0 0 0

It can be set from 00.0001 up to 99.9999.

The decimal point is set to 4 decimal places.

9 9 9 9 9 9

„0“ is not accepted!

4.5 Decimal point (totaliser)

d P . t o t

The decimal point defines the way of displaying the count values. It does not affect counting.

0

0 no decimal place

0.0 one decimal place

0 0 0 0

0.00 two decimal places

0.000 three decimal places

4.6 RESET-Mode (totaliser)

r E S . t o t

r r r r n E L

manual reset via the red RESET key and electrical reset via the RESET input

n o r E S

no reset (red RESET key and RESET input locked)

E L r E S

only electrical reset via the RESET input

r r r r n r E

only manual reset via the red RESET key

4.7 Multiplying factor (frequency meter)

F R c . t R c

0 0 0 0 0 0

It can be set from 00.0001 up to 99.9999.

The decimal point is set to 4 decimal places.

9 9 9 9 9 9

„0“ is not accepted!

4.8 Dividing factor (frequency meter)

d i u . t R c

0 0 0 0 0 0

It can be set from 00.0001 up to 99.9999.

The decimal point is set to 4 decimal places.

9 9 9 9 9 9

„0“ is not accepted!

4.9 Decimal point (frequency meter)

d P . t R c

The decimal point defines the resolution in the selected measuring range 1/min or 1/sec

0

0 no decimal place

0.0 one decimal place

0 0 0 0

0.00 two decimal places

0.000 three decimal places

4.10 Display mode (frequency meter)

d i . S P n r

S E L - i

Value conversion and display in 1/s

r r . n - i

Value conversion and display in 1/min

4.11 Max. time to wait until „0“ is displayed (frequency meter)

This parameter indicates, how long it takes, when measuring is active, until „0“ is displayed.

t w a i t . t 0

0 0 . 1

Max. time to wait 00.1 s (min. value)

9 9 . 9

Max. time to wait 99.9 s

4.12 End of programming

E n d P r o

n o

The programming routine is repeated once more. The values set until now can be checked and modified.

Y E S

The programming routine will be left and all values set will be stored as new parameters. Afterwards the device is ready for operation.

Electronic display counter with 2 totalising ranges

Codix 52U: basic operating mode

000000

1. Description

- 6-digit display counter with Reset function
- Red LED display, character height 8 mm
- Display range 0 ... 999 999
- Leading zeros suppression
- Programming via two setting keys on the front side
- During programming, the display guides the user with text prompts

2. Inputs

INP A

Dynamic count input Counter 1 and Counter 2.

RESET

Dynamic RESET input. Linked in parallel to the red RESET key. Sets the counter to zero. Can be adjusted individually for Counter 1 and Counter 2.

3. Selection of the displayed value

Pressing the right key allows switching between the display of totaliser 1 and the display of totaliser 2. Press the key briefly to display for 2 seconds the current function ("total1" or "total2"). If, during this period of time, the right key is pressed a second time, the device switches to the next function and displays a confirmation ("total1" or "total2") for 2 seconds. Then, the value of the selected function is displayed.

4. Programming routine

The programmable parameters of the device are described below, in the order in which they can be set. The device is fully programmed after one pass of the routine.

The first values stated correspond to the factory settings

4.1 Polarity of the inputs

inp01

npn switching for 0 V

pnp switching for +UB

4.2 Switching on the 30 Hz filter (INP A)

f1tEr

The filter provides input damping*

off

30 Hz filter off (fmax)

on

30 Hz filter on

4.3 Multiplying factor

Frc0t

0.0000

It can be set from 00.0001 up to 99.9999.

The decimal point is set to 4 decimal places.

„0“ is not accepted!

999999

4.4 Dividing factor

div0t

0.0000

It can be set from 00.0001 up to 99.9999.

The decimal point is set to 4 decimal places.

„0“ is not accepted!

999999

4.5 Decimal point

dp0t

The decimal point defines the way of displaying the count values. It does not affect counting.

0

0 no decimal place

0.0 one decimal place

0.00 two decimal places

0.000 three decimal places

0.000

4.6 RESET mode (totaliser 1)

res01

rrrEt

manual reset via the red RESET key and electrical reset via the RESET input

no res

no reset (red RESET key and RESET input locked)

Et res

only electrical reset via the RESET input

rrrrEt

only manual reset via the red RESET key

* where bounce occurs, e.g. with contacts

4.7 RESET Mode (totaliser 2)

r E S n r 2

p n r r E L

manual reset via the red
RESET key and
electrical reset via the RESET
input

n o r E S

no reset (red RESET key and
RESET input locked)

E L r E S

only electrical reset via the
RESET input

p n r r o r E

only manual reset via the red
RESET key

4.8 End of programming

E n d P r o

n o

The programming routine is
repeated once more. The val-
ues set until now can be
checked and modified.

y E S

The programming routine will be
left and all values set will be
stored as new parameters.

Afterwards the device is ready
for operation.

INP A

Dynamic count input for the totaliser.

INP B

Start/Stop or gate input for time meter
(independent of the input mode)

RESET

Dynamic RESET input. Linked in parallel to the red RESET key. Sets the counter to zero. Can be adjusted individually for the totaliser and the time meter.

3. Selection of the displayed value

Pressing the right key allows switching between the totaliser display and the time meter display. Press the key briefly to display for 2 seconds the current function ("total" or "time"). If, during this period of time, the right key is pressed a second time, the device switches to the next function and displays a confirmation ("total" or "time") for 2 seconds. Then, the value of the selected function is displayed.

4. Programming routine

The programmable parameters of the device are described below, in the order in which they can be set. The device is fully programmed after one pass of the routine.

The first values stated correspond to the factory settings

Electronic totaliser and time meter

Codix 52U: basic operating mode

t o t t i

1. Description

- 6 digit totaliser and time meter with Reset function
- Red LED display, character height 8 mm
- Display range 0 ... 999 999
- Leading zeros suppression
- Programming via two setting keys on the front side
- During programming, the display guides the user with text prompts
- Operation indicator: the decimal point of the lowest digit blinks while the count is active.
- Time meter operating modes:
 - Counting while INP B is inactive "GAtE.Lo"
 - Counting while INP B is active "GAtE.hi"
 - Count Start/Stop with INP B edge B "Inb.Inb"
- Counting ranges: h; min; s; h.min.s

2. Inputs

4.1 Polarity of the inputs

i n P o L

n P n

npn: switching for 0 V

P n P

pnp: switching for +U_B

4.2 Switching on the 30 Hz filter (INP A, INP B)

F i l t E r

The filter provides input
damping*

o F F

30 Hz filter off (fmax)
Count and start/stop inputs not
damped

o n

30 Hz filter on
Count and start/stop inputs
damped

* where bounce occurs, e.g. with contacts

4.3 Multiplying factor (totaliser)

FRctot

010000

It can be set from 00.0001 up to 99.9999.

The decimal point is set to 4 decimal places.

999999

„0“ is not accepted!

4.4 Dividing factor (totaliser)

drtot

010000

It can be set from 00.0001 up to 99.9999.

The decimal point is set to 4 decimal places.

999999

„0“ is not accepted!

4.5 Decimal point (totaliser)

dp tot

The decimal point defines the way of displaying the count values. It does not affect counting.

0

0 no decimal place

0.0 one decimal place

0000

0.00 two decimal places

0.000 three decimal places

4.6 RESET mode (totaliser)

resetot

prrenel

manual reset via the red RESET key and electrical reset via the RESET input

no reset

(red RESET key and RESET input locked)

el reset

only electrical reset via the RESET input

prrenr

only manual reset via the red RESET key

4.7 Input mode (time meter)

stret

stelt

Start/Stop via Inp B. Counting while Inp B (Gate) not active or open

stelh

Start/Stop via Inp B. Counting while Inp B (Gate) active (High level with pnp; Low level with npn)

inb inb

Count Start/Stop via INP B (LOW-HIGH edge with pnp; HIGH-LOW edge with npn). Every active edge changes the counter status.

4.8 Operating mode (time meter)

tpodE

5E

Time unit: seconds (accuracy depending on position of the decimal point*)

tpi

Time unit: minutes (accuracy depending on position of the decimal point*)

hour

Time unit: hours (accuracy depending on position of the decimal point*)

hpi

Time units: Hours:Minutes:Seconds (decimal point setting is ignored)

4.9 Decimal point (time meter)

dp tin

The decimal point defines the resolution of the programmed time unit.

0

1

0.0 1/10 (0,1)

0000

0.00 1/100 (0,01)

0.000 1/1000 (0,001)

*0, 0.1, 0.01, 0.001 means: time measurement in 0, 0.1, 0.01, 0.001 time units

4.10 RESET mode (time meter)

`rES.ti`

`ppRnEt`

manual reset via the red RESET key and electrical reset via the RESET input

`no rES`

no reset (red RESET key and RESET input locked)

`Et rES`

only electrical reset via the RESET input

`ppRnrE`

only manual reset via the red RESET key

4.11 End of programming

`EndPro`

`no`

The programming routine is repeated once more. The values set until now can be checked and modified.

`YES`

The programming routine will be left and all values set will be stored as new parameters.

Afterwards the device is ready for operation.

Electronic time meter with 2 time ranges

Codix 52U: basic operating mode

`ti.ti`

1. Description

- 6 digit time meter with Reset function
- Red LED display, character height 8 mm
- Display range 0 ... 999 999
- Leading zeros suppression
- Programming via two setting keys on the front side
- During programming, the display guides the user with text prompts
- Operation indicator: the decimal point of the lowest digit blinks while the count is active
- Time meter operating modes:
 - Counting while INP B is inactive "GATE.Lo"
 - Counting while INP B is active "GATE.hi"
 - Count Start/Stop with INP B edge (Inb.Inb)
 - Count Start with INP A edge, count Stop with INP B edge (InA.InB)

2. Inputs

INP A

Start input (depending on the input mode chosen)

INP B

Time meter Start/Stop or gate input (depending on the input mode chosen)

RESET

Dynamic RESET input. Linked in parallel to the red RESET key. Resets the counter to zero. Can be adjusted individually for Counter 1 and Counter 2.

3. Selection of the displayed value

Pressing the right key allows switching between the display of time meter 1 and the display of time meter 2. Press the key briefly to display for 2 seconds the current function ("time1" or "time2"). If, during this period of time, the right key is pressed a second time, the device switches to the next function and displays a confirmation ("time1" or "time2") for 2 seconds. Then, the value of the selected function is displayed.

4. Programming routine

The programmable parameters of the device are described below, in the order in which they can be set. The device is fully programmed after one pass of the routine.

The first values stated correspond to the factory settings

4.1 Polarity of the inputs

`inpOL`

`npn`

npn: switching for 0 V

`ppn`

pnp: switching for +UB

4.2 Switching on the 30 Hz filter (INP A, INP B)

`FiLkEr`

The filter provides input damping*

`off`

30 Hz filter off (fmax)
Start/Stop inputs not damped

`on`

30 Hz filter on
Start/Stop inputs damped for use with mechanical switches

* where bounce occurs, e.g. with contacts

4.3 Input mode (time meter)

5tRr t

GRt EL a

Start/Stop via Inp B. Counting while Inp B (Gate) not active or open

GRt Ehi

Start/Stop via Inp B. Counting while Inp B (Gate) active (High level with pnp; Low level with npn)

inb inb

Count Start/Stop via INP B (LOW-HIGH edge with pnp; HIGH-LOW edge with npn). Every active edge changes the counter status.

inR inb

Count start via INP A, stop via INP B. (LOW-HIGH edge with pnp; HIGH-LOW edge with npn)

4.4 Operating mode

tP q a d E

5 E E

Time unit: seconds (accuracy depending on position of the decimal point*)

P q i n

Time unit: minutes (accuracy depending on position of the decimal point*)

hour

Time unit: hours (accuracy depending on position of the decimal point*)

h P q i n S

Time units: Hours:Minutes:Seconds (decimal point setting is ignored)

4.5 Decimal point

d P t n

The decimal point defines the resolution of the programmed time unit.

0

0 1
0.0 1/10 (0,1)

0000

0.00 1/100 (0,01)
0.000 1/1000 (0,001)

4.6 RESET mode (time meter 1)

r E S n r i

P q R n E L

manual reset via the red RESET key and electrical reset via the RESET input

n a r E S

no reset (red RESET key and RESET input locked)

E L r E S

only electrical reset via the RESET input

P q R n r E

only manual reset via the red RESET key

4.7 RESET mode (time meter 2)

r E S n r i

P q R n E L

manual reset via the red RESET key and electrical reset via the RESET input

n a r E S

no reset (red RESET key and RESET input locked)

E L r E S

only electrical reset via the RESET input

P q R n r E

only manual reset via the red RESET key

4.8 End of programming

E n d P r o

n a

The programming routine is repeated once more. The values set until now can be checked and modified.

y E S

The programming routine will be left and all values set will be stored as new parameters.

Afterwards the device is ready for operation.

*0, 0.1, 0.01, 0.001 means: time measurement in 0, 0.1, 0.01, 0.001 time units

5. Technical data

Supply voltage

DC power supply: 10 ... 30 V DC/max. 55 mA
with inverse-polarity
protection

Display: 6 digits, red 7 segment
LED display, height 8 mm

Data retention: EEPROM

Polarity of the inputs:

Programmable, npn or pnp
for all inputs

Input resistance: appr. 5 k Ω

Count frequency:

DC power supply	24 V	12 V	10 ...30 V
Input level:	Standard 5V		
typ. low level	2,5 V	2,0 V	1,0 V
typ. high level	22,0 V	10 V	4,0 V
Fmax:*	kHz	kHz	kHz
tot.tac	35	20	8
tot.tot	60	20	8
tot.ti ¹⁾	40	20	8
tot.ti ²⁾	15	10	8

* at maximum frequency square wave pulses 1:1

- 1) Start Gate.Lo Inp B not activ
- 2) Start InpB.InpB and Inp B connected
with Inp A

Frequency measurement:

Accuracy : < 0.1 %

Measuring principle:

< 38 Hz: period measurement
> 38 Hz: gating time measurement
gating time = 26,3 ms

Time count ranges:

Seconds 0,001 s ... 999999 s
Minutes 0,001min ... 999999 min
Hours 0,001 h ... 999999 h
h.min.s 00 h 00 min 01 s
... 99 h 59 min 59 s
Accuracy <50 ppm

Minimum pulse length for the Reset input:

5 ms

Input sensitivity:

Standard sensitivity:

Low: 0 ... 0,2 x UB [V DC]
High: 0,6 x UB ... 30 [V DC]

4 ... 30 V DC level:
Low: 0 ... 2 V DC
High: 4 ...30 V DC

Pulse shape: any,
Schmitt-Trigger inputs

Ambient temperature:

-20 ... +65 °C at 10 ... 26 V DC
-20 ... +55 °C at >26 ... 30 V DC

Storage temperature:

-25 ... +70 °C

Altitude: to 2000 m

EMC:

Noise emission EN 55 011 Class B
Noise immunity EN 61 000-6-2

Housing: For front panel mounting:
48 x 24 mm acc. to DIN
43700, RAL7021, dark grey

Weight: appr. 50 g

Protection: IP 65 (front)

Cleaning: The front of the units is to
be cleaned only with a soft
wet (water !) cloth.

6. Terminal assignment

- 1 10 ... 30 V DC
- 2 0 V GND
- 3 INP A
- 4 INP B
- 5 Reset

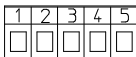

8. Ordering code:

6.52U.012.3X0

Input sensitivity

0 = Standard

A = 4 ... 30 V DC level

7. Delivery includes:

- 1 Digital display
- 1 Panel mounting clip
- 1 Bezel for screw mounting, panel cut out 50 x 25 mm
- 1 Bezel for clip mounting, panel cut out 50 x 25 mm
- 1 Seal
- 1 Multilingual operating instructions

9. Dimensions:

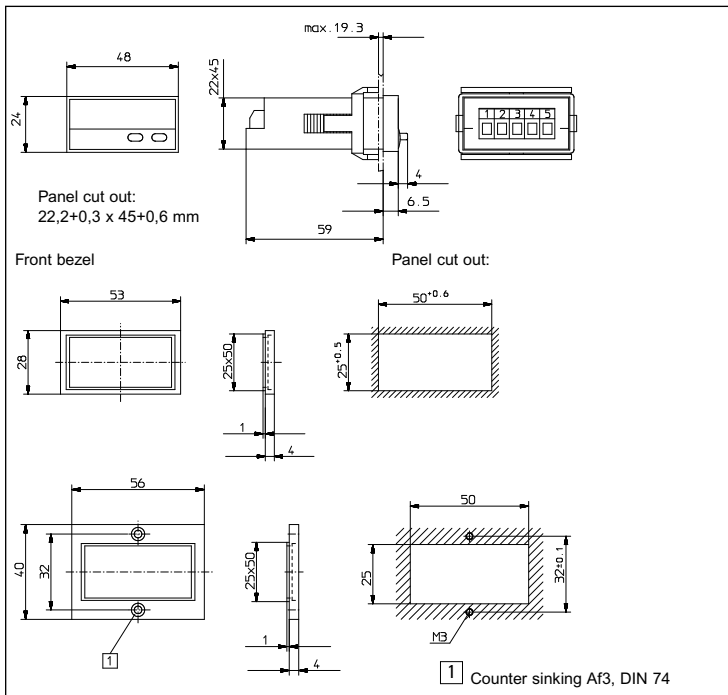

Trumeter (The Americas)

Trumeter, 702 S. Military Trail, Deerfield Beach, Florida
FL 33442, USA
Tel: +1 954 725 6699
Email: sales.usa@trumeter.com

Trumeter (Europe)

Trumeter, Pilot Mill, Alfred Street, Bury, Lancashire
BL9 9EF, United Kingdom
Tel: +44 161 674 0960
Email: sales.uk@trumeter.com

Asia Pacific Distributor

Innovative Design Technologies Sdn. Bhd, Lot 5881, Lorong Iks Bukit Minyak 1
Taman Perindustrian Iks, 14000 Bukit Tengah
Penang, Malaysia
Web: www.idtworld.com
Tel: + 604 5015700
Email: info@idtworld.com